

GE
Water & Process Technologies

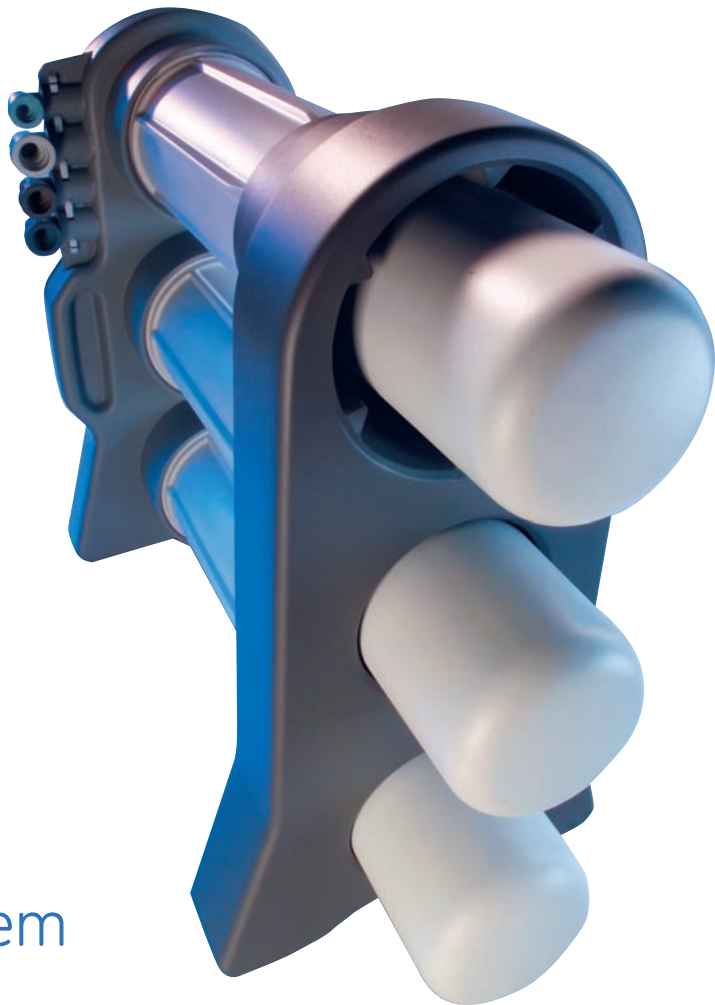

Merlin™
Point-of-Use
Drinking Water System



imagination at work

Merlin point-of-use Reverse Osmosis System

The biggest innovation in home RO technology in 30 years!

We've done it again. GE Water & Process Technologies has achieved a revolutionary breakthrough in the water treatment industry. Out-of-the-box thinking and years of research have produced a totally new point-of-use drinking water system.

The new Merlin RO System features continuous-flow water production, so a storage tank is no longer required. The unit operates on line pressure, which eliminates the need for an electrical

pump in most applications. The patented high-production, low-energy membrane reduces impurities in up to 490.2* gpd!

This high-capacity performance creates new opportunities for commercial applications – at the price of a residential system.

Big innovation, bigger opportunities.

Like no other system!

- Continuous flow – no storage tank necessary
- Uses line pressure only (>40 psi/2.76 bar)
- 1/2 gpm (1.89 lpm) permeate rate @50 psi (3.44 bar) + 77°F (25°C)
- Requires no pump, no electricity (>40 psi/2.76 bar)
- Compact design – fits easily under sink
- Water Quality Association Gold Seal – NSF/ANSI 58 Certified
- Consistent membrane efficiency
- Complete product literature and training support
- Consistent high recovery system means less water going to drain
- Multiple dispensing locations off one system

*At 50 psi (3.44 bar), 77°F (25°C), 750 ppm NaCl

TOUGH STUFF
High-durability Noryl® and polypropylene plastic construction provide years of dependable service

ALL THE RIGHT CONNECTIONS
Engineered for the fewest number of connection points – less chance of leaks

NO TANKS!
Loss of tank pressure and contamination worries are eliminated

SLEEK, GOOD LOOKS
Contemporary, appliance-style design creates consumer appeal

NEVER RUNS DRY
Continuous permeate water flows at 1/2 gpm (1.89 lpm)*



Tested and Certified by the Water Quality Association according to NSF/ANSI 58

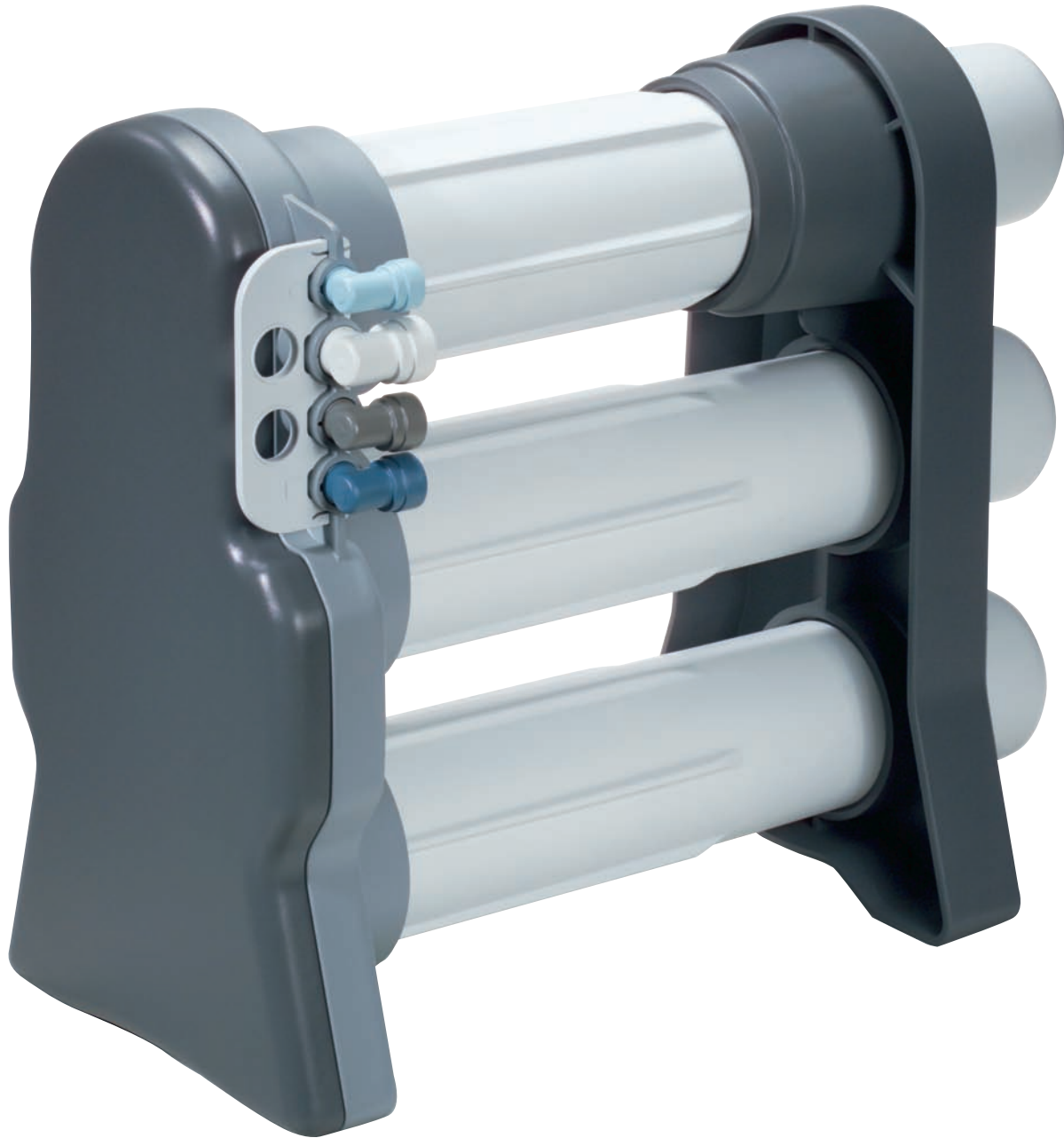

IT'S A SNAP

Quick-latch snaps into place and locks down all four tubing connectors in one easy step

STEADY STREAM OF INCOME

Custom replacement components will be made available only through professional channels

BUILT-IN CONVENIENCE

System's support leg also serves as a handy sump wrench

AT YOUR SERVICE

Custom high-flow faucet (with air gap) developed specifically for this system

FITS IN NICELY

Stand-alone compact profile takes up less space than other bulky systems

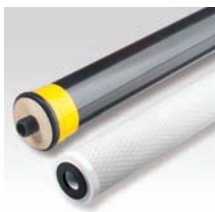

A world of possibilities

Safe, clean water is in the news and on the minds of today's consumers. The Merlin Reverse Osmosis System addresses those concerns. Water treatment professionals will now have a truly innovative product that opens doors and provides homeowners with effective, economical solutions.

By spanning the residential and light commercial markets, the Merlin Reverse Osmosis System presents unique opportunities for growth. The breakthrough high-flow technology allows one system to support a broad range of applications – all at a price point well below current commercial systems.

Endless sales potential

- Residential
- Business Offices
- Humidifiers
- Steamers
- Restaurants
- Pubs
- Coffee Makers
- Water Coolers
- Ice Makers
- Aquariums
- Photography Processing
- Misters
- Spot-free Rinse
- Unlimited possibilities...



How does your current system compare?

	Merlin RO	Standard RO
Average Daily Production Rate*	490 gpd	10-50 gpd
Water Storage Tank	None needed	Integral part of system
Install Time	1 Hour	Up to 4 Hours*
System Efficiency**	22.7%	As little as 5%

*Based on inlet conditions of 50 psi (3.44 bar), 77°F (25°C), 750 ppm NaCl.

**Efficiency rating is identical to recovery rating when the system is tested without a storage tank or when a storage tank is bypassed.

Minimum and Maximum Operating Conditions

Condition*	Minimum	Maximum
Inlet Pressure	40 psi (2.76 bar)	80 psi (5.52 bar)
Inlet Temperature	40°F (4.44°C)	100°F (37.78°C)
Inlet TDS	50 mg/L	2,000 mg/L
Inlet Hardness	0 mg/L - (0 grain)	171 mg/L - (10 grain)
Inlet Chlorine	0 mg/L	1.0 mg/L
Inlet Iron	0 mg/L	.1 mg/L
Inlet Manganese	0 mg/L	.05 mg/L

*System is designed for use on potable water sources only.

Tubing/Fitting Dimensions

- Inlet Tubing** → 4 feet of 1/2" natural tubing
(1.22 meters of 12.7 mm natural tubing)
- Concentrate Tubing** → 4 feet of 3/8" black tubing
(1.22 meters of 9.53 mm black tubing)
- Permeate Tubing** → 4 feet of 3/8" blue tubing
(1.22 meters of 9.53 mm blue tubing)
- Drain Tubing** → 3 feet of 1/2" red tubing
(for airgap installation) (0.91 meters of 12.7 mm red tubing)
- Drain Connection** → 3/8" or 1/2"
(9.53 mm or 12.7 mm)
- Carbon Post Filter** → 3/8" quick disconnect fittings
(9.53 mm quick disconnect fittings)

Inlet Connectors

- Option 1** → 1/2" x 1/2" x 1/2" tee
(12.7 mm x 12.7 mm x 12.7 mm tee)
- Option 2** → 5/8" x 5/8" x 1/2" tee
(15.875 mm x 15.875 mm x 12.7 mm tee)
- Option 3** → 1/2" x 1/2" threaded x 1/2" tee
(12.7 mm x 12.7 mm threaded x 12.7 mm tee)
- Option 4** → 0.59" x 0.59" x 1/2" tee
(15 mm x 15 mm x 12.7 mm tee)

Filter/Membrane Performance Specifications

Filter Type	Dimensions		Flow Rate*	Average Life
	Length	Diameter		
Carbon Prefilter	17.0" (43.2 cm)	2.9" (7.4 cm)	3.75 GPM (14.2 LPM)	6 months (5,000 gal) (18,925 liters)
RO Element	18.75" (47.6 cm)	3.16" (8.0 cm)	0.25 GPM (0.95 LPM)	2-4 years
Carbon Postfilter	10.5" (26.7 cm)	2.6" (6.6 cm)	.750 GPM (2.8 LPM)	6 months

*Based on: 50 psi (3.44 bar), 77°F (25°C), 750 mg/L NaCl, 22.7% Recovery, 1.0 mg/L inlet chlorine

Options

- Booster Pump → For low pressure applications
- Membrane Rinse System → Permeate flushing accumulator
- 10-micron Sediment Prefilter → For commercial applications and non-chlorinated water supplies

Outline Dimensions – Inches (cm)

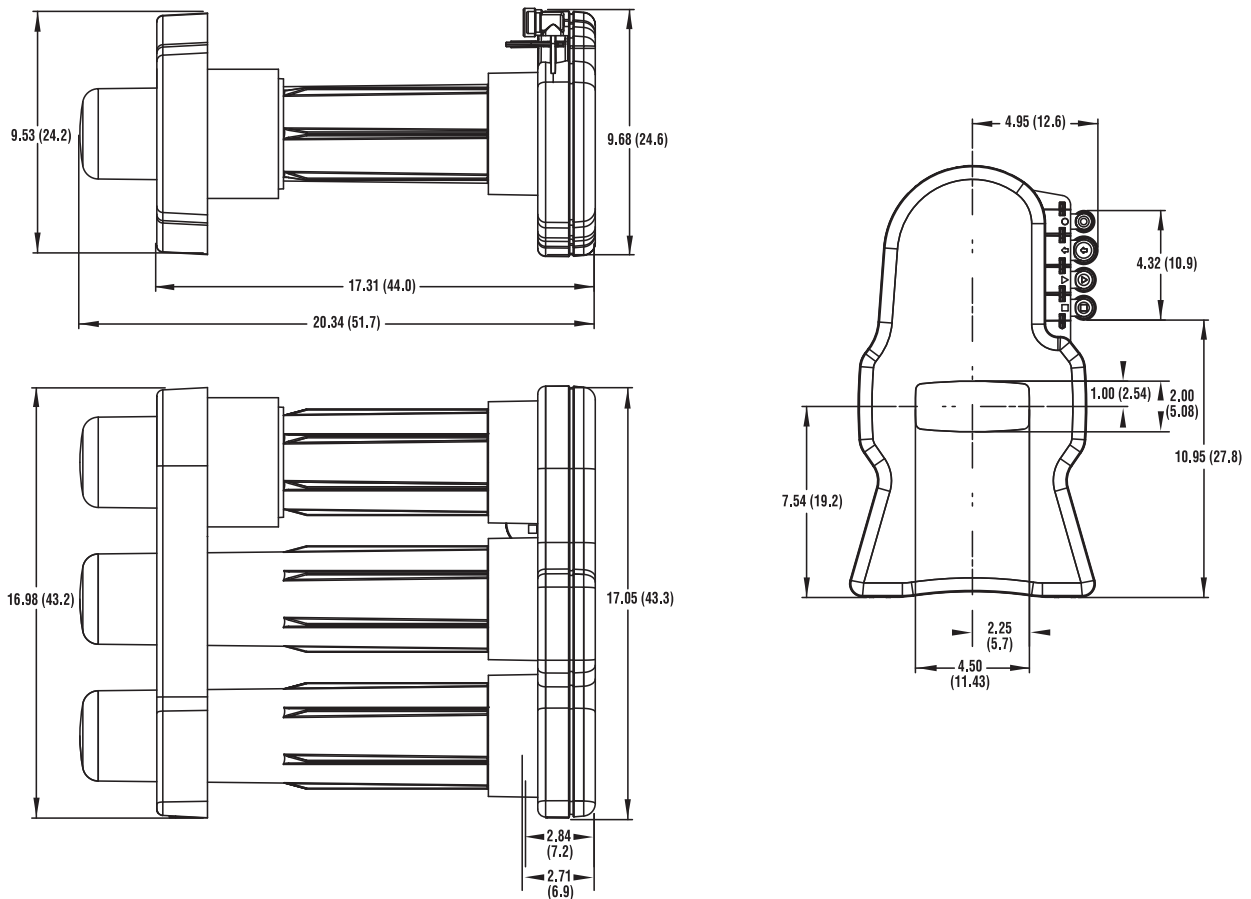

Merlin System Flow Rates*

Based on 750 ppm TDS Inlet Water

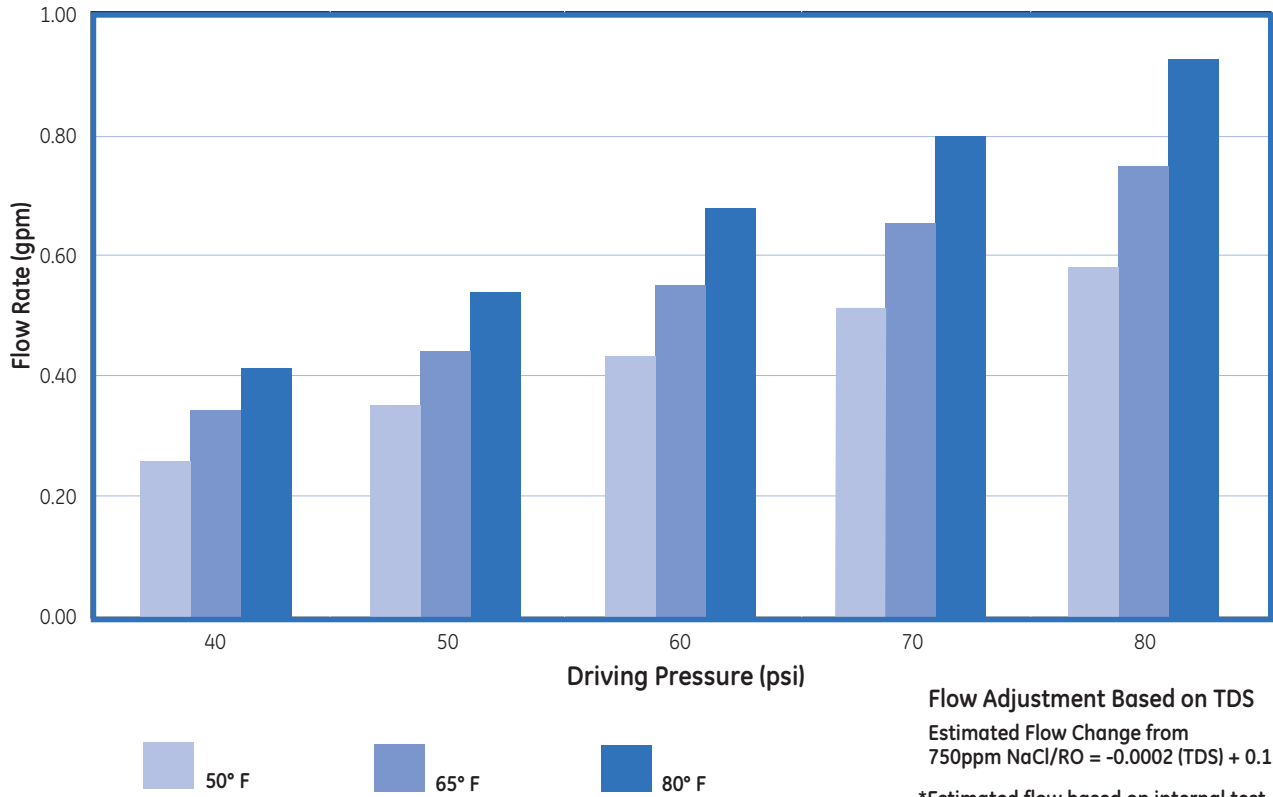

Flow Adjustment Based on TDS

Estimated Flow Change from
750ppm NaCl/RO = $-0.0002 \text{ (TDS)} + 0.15$

*Estimated flow based on internal test data. Actual performance may vary.

Performance Specifications[†]

Specification	Average
Permeate Flow Rate ^{††}	0.50 Gallons/Minute (1.89 Liters/Minute)
TDS Rejection (NaCl) ^{††}	90.7%

[†]Based on 50 psi (3.44 bar), 77°F (25°C), 750 mg/L NaCl, 24% recovery.

^{††}For complete WQA test results to NSF/ANSI 58 Standard, see Merlin product data sheet P/N 1263717.

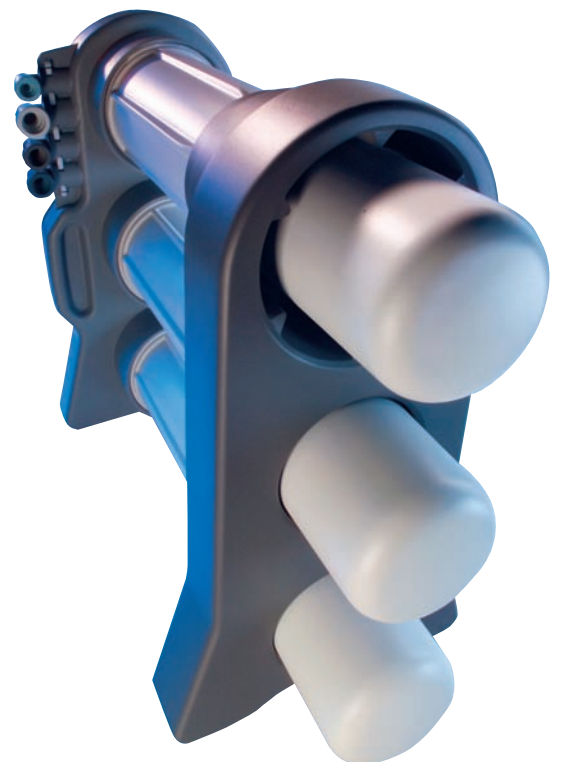

North American Sales
5730 N. Glen Park Road
Milwaukee, WI
53209-4403
USA
(262) 238-4400 Phone
(262) 238-4404 Fax

For more information:
Call GE
Water & Process Technologies
at (800) 279-9404,
or visit www.gewater.com

Europe/Middle East/
Africa Operations
1, Allée du 1er Mai
77183 Croissy-Beaubourg
FRANCE
+33 1 60 37 59 60 Phone
+33 1 60 37 59 37 Fax

Asia/Pacific Sales
1159 Kang Qiao Road East,
No. 51, Building #2
Shanghai, China 201315
+86-21-6818-2900 Phone
+86-21-6818-2933 Fax

This system has been tested according to NSF/ANSI 58 for reduction of substances listed below. The concentration of the indicated substances in water entering the system was reduced to a concentration less than or equal to the permissible limit for water leaving the system, as specified in NSF/ANSI 58. The substances are: Arsenic [Pentavalent (≤ 50 ppb)], Barium, Cadmium, Chromium (Hexavalent), Chromium (Trivalent), Copper, Fluoride, Lead, Nitrate, Nitrite, Radium 226/228, Selenium and TDS.



This product incorporates
Genuine John Guest
Component Parts.
for High Quality and Reliability



©2008, General Electric Company.
Printed in USA, P/N 1243155 Rev.F